



The Gold Standard
– Since 1948 –

ARBITRATION GUIDELINES

In-Lane and Online

EFFECTIVE DATE:

June 1, 2026

The following guidelines are established and provided by the National Auto Auction Association (“NAAA”) for the benefit of its member auctions. NAAA is a non-profit trade association that exists to assist its members in enhancing performance in the wholesale auto auction industry operations. Although these recommended guidelines are designed to encourage consistency and fair dealing in the wholesale auction industry, they are not enforced or monitored by NAAA, as the trade association is not a governing or enforcement body. The actual contractual relationship among the auction, in each case, and its buyer and seller customers is determined by the auction itself, according to its policies and terms and conditions. The member auctions are free to adopt the NAAA guidelines, in whole or in part, into their contractual relationships at their sole discretion.

I General Guidelines

1 Fair and Ethical Sale

The sales made at an auction are intended to promote fair and ethical treatment to both the buyer and seller. If auction determines that the transaction is not fair and ethical to either party, the seller and the buyer agree that auction may cancel the sale, at its sole discretion. Federal, State, and Local laws supersede these guidelines where applicable.

2 Auction VIN Guidelines

All vehicles consigned must have a visible public Vehicle Identification Number (VIN) attached to the vehicle by the manufacturer or state inspector (state-reassigned VIN only). Those vehicles having a reassigned VIN by the State in place of the original VIN must be announced or will be subject to arbitration. Auction reserves the right to refuse the sale of any vehicle in which the VIN appears to be altered in any way.

3 Auction Role in Sale

- a. Auction makes no representations or guarantees on any vehicle sold or offered for sale.
- b. Auction is not a party to the contract of the sale. The sales contract is between the seller and buyer only.
- c. The auction must process all vehicle sales occurring on its premises or online platform(s) without exception. Failure to do so will result in suspension of trading privileges.
- d. Auction reserves the right to review any audio/video documentation to verify the accuracy of a sale.
- e. Any vehicle consigned with auction is subject to government inspection, with or without prior notice, by the FBI, State Police, National Auto Theft Bureau, Local Police authorities, or any other governmental or quasi-governmental agency.
- f. Auction management reserves the right to reject any vehicle, at any time for any reason.
- g. Auction management makes the binding decision upon both the buyer and seller on all arbitration matters.

II Sale Light System

Auction has a standard light/video display system to describe the condition and/or disclosures related to the vehicle being offered for sale. The system is defined as:

● Green — Ride & Drive

Vehicle is guaranteed by seller in accordance with these guidelines. Any defects or issues requiring disclosure should be announced using the green and yellow lights simultaneously.

● Yellow — Limited Guarantee

Seller has made announcements that qualify/clarify the condition of the vehicle and/or its equipment and limit arbitration, either in conjunction with the green light or when "Limited Guarantee" is announced.

● Red — Limited As-Is

Vehicle is not guaranteed and only qualifies for arbitration given certain conditions as detailed in these guidelines. Local auction policy dictates which vehicles automatically sell red light based upon the sale price, model year and/or mileage.

● Blue — Title Attached / Unavailable / Absent ("TA" in each instance)

Title is not present at time of sale. If seller does not utilize the blue light or announce it as TA, buyer may arbitrate based upon local auction policy regarding the time frame within which seller must present the title.

ANNOUNCEMENT / LIGHT USAGE LEGEND

Announcement Type	Green	Yellow	Red
<i>Ride & Drive</i>	✓	N/A	N/A
<i>Ride & Drive with Caution Announcement</i>	✓	✓	N/A
<i>Limited Guarantee</i>	N/A	✓	N/A
<i>Limited As-Is</i>	N/A	N/A	✓

III Seller Responsibilities

1 Prohibited Announcements

- a. Sellers are prohibited from using ambiguous, confusing, or deceptive announcements or disclosures as these may be grounds for arbitration and the sale may be voided or arbitrated. Auction has discretion in determining if announcements or disclosures are ambiguous, confusing, or deceptive.
- b. Sellers are prohibited from using generic announcements such as "No Arb for [defect]" (e.g., "No Arb for Oil Leaks") to avoid arbitration, as these announcements provide no actionable information about the vehicle's condition. Instead, sellers should announce the specific defect as per NAAA sale light guidelines and recommended announcements (e.g., "Engine Problem") or announce the vehicle as Red Light/As-Is.

2 Accuracy of Representations

Seller will be held responsible for the accuracy and completeness of all representations or descriptions. This includes handouts, catalogues, vehicle markings, condition information or vehicle listings and verbal or written statements made by seller, auction, auctioneer or selling representative at the time of sale. This includes the condition report written by or on behalf of the seller as per the "NAAA Auction Condition Report Position Statement." The seller understands that the sale light/video display is a binding representation of vehicle condition and therefore the seller is responsible for ensuring that their vehicles are offered for sale under the correct light.

3 Mileage Disclosures

Mileage announcements are not required for vehicles classified as exempt from odometer or title disclosure laws. However, any mileage representation, whether verbal, written, or electronic—is binding, and the vehicle remains subject to arbitration for mileage discrepancies. Exempt status does not relieve the seller of the obligation to disclose any known or apparent mileage or odometer inconsistencies.

4 Title Discrepancies

Title discrepancies must be announced including, but not limited to not actual miles, salvage, theft recovery, stolen vehicle, flood damage, and Lemon Law buybacks.

5 Third Party Sellers

If a vehicle is being offered for sale by a third party on behalf of the owner, an announcement of "3rd party seller" is required. Disclosure requirements are subject to local auction policy.

6 Mechanical Modifications

Sellers must disclose major mechanical modifications or alterations including, but not limited to, engine tuners or programming, high performance or racing alterations, turbo chargers, and emissions. Each major modification should be specified in the announcement.

7 Warning Lights & Diagnostic Codes

The disclosure of warning lights or diagnostic trouble codes does not relieve the seller of arbitration responsibilities as outlined in these guidelines. The underlying condition or defect causing the light or code remains subject to arbitration within the applicable time frame and dollar threshold specified in Appendix 1.

8 Restrictive Component Announcements

Sellers choosing to make a specific or restrictive announcement related to a problem or defect with a major component (e.g., upper engine noise) remain subject to arbitration claims related to other unspecified parts or features of that component (e.g., lower engine problems).

9 Manufacturer Warranty Coverage

If the manufacturer's warranty coverage is still in effect for all or part of a vehicle sold at auction, it does not negate the buyer's right to arbitrate the vehicle. Announcements are still required if the repair cost exceeds the thresholds under these guidelines.

10 Buyer Reimbursement

In the event of a buyer's successful arbitration, the seller is responsible for reimbursement of reasonable and documented expenses incurred by the buyer. Reimbursements qualifying under these guidelines will be at the sole discretion of the Auction and will be limited to commercially reasonable costs based on local auction (wholesale) repair or transportation rates. Lost profit and commissions along with marketing and reconditioning costs are not reimbursable under any circumstances.

11 Payment Hold & Return

Seller will not be paid for a vehicle in arbitration until arbitration is settled and the vehicle sale is final, as determined by the auction. If the auction rules in favor of the buyer in an arbitration claim resulting in the sale transaction being voided and the seller has already been paid, the seller is required to promptly return the payment to the auction.



IV Buyer Responsibilities

1 Pre-Bid Inspection Responsibility

- a. Prior to placing bids, the buyer is responsible for inspecting the vehicle, listening to and reviewing any verbal or written announcements and disclosures made by the seller, auction, auctioneer or selling representative.
- b. Buyers are also responsible for reviewing all pertinent information available online, including, but not limited to, announcements, disclosures, condition reports, pictures, videos and vehicle listings.
- c. Buyers are also responsible for observing and understanding the sale lights (Green, Green/Yellow, Yellow, Red, and/or Blue), which identify various sale conditions for the vehicle.
- d. Once the vehicle is sold, the buyer must review the Auction sales receipt or appropriate document to confirm the vehicle price, disclosures and announcements are correct.

2 Vehicle Reconditioning and Repairs

Following a successful arbitration claim, the buyer will be responsible for, and will not be reimbursed by the seller or auction, any repairs, reconditioning, or enhancements made to the vehicle prior to its return to the auction. This provision does not apply to vehicles arbitrated for undisclosed conditions not detectable through vehicle inspection, including, but not limited to, Not Actual Miles, salvage, theft recovery or stolen vehicle status, flood damage, and Lemon Law buybacks.

3 Financial Responsibility

The buyer assumes all risk of loss and is financially responsible for any unpaid vehicle purchase price plus any fees while the vehicle sale is pending under an arbitration claim.

4 Gate Release Documentation

The buyer or buyer's agent (transporter or driver) must document any damage in writing or acceptable electronic format prior to taking possession of the vehicle and removing it from the auction or facilitation service provider's location. Auctions, facilitation service providers and sellers will not be responsible for any damage not identified and properly documented at the time of gate release if the vehicle is removed from the location.

5 Claims Against Title or Possession

The buyer shall not surrender possession of the vehicle to any claimant, except as required by legal process, nor shall buyer voluntarily pay or acknowledge the validity of any claim, without the prior approval of auction. Time is of the essence. Any failure on the part of the buyer, after becoming aware of said claim, to notify auction of any claim in a timely manner or failure of the buyer to cooperate in defending any such claim shall relieve auction and seller of any liability under these guidelines.

6 Vehicle Return Requirements

- a. The vehicle must be returned in a timely manner as directed by auction.
- b. The vehicle must be returned in the same or similar condition, consistent with its marketable condition at the time of sale. The auction has sole discretion in determining the condition of the vehicle at time of return.
- c. Buyer assumes all risk of loss for any vehicle delivered to and/or left on auction premises without auction knowledge.
- d. The buyer assumes all risk of loss until the vehicle is received, inspected and approved as a return by auction management.



V Arbitration Guidelines and Limitations

The buyer must initiate an arbitration claim for a vehicle with the auction in accordance with the time period and limitations noted below or the arbitration claim will be denied. Vehicles must be returned to auction as outlined in item 6 of Buyer Responsibilities in these guidelines.

1 Time Period

Refer to Appendix I for arbitration time periods. Sale day is Day 1. The Arbitration time period shall end at the close of business as determined by each local auction on the last calendar day in the time period.

2 Process

- a. The buyer may arbitrate a vehicle for any single undisclosed or unannounced mechanical defect (including those outlined in Appendix I) with a repair cost exceeding the dollar thresholds based on the purchase price of the vehicle as defined below. Any such defect must meet the criteria defined in these guidelines subject to the restrictions of the light under which the vehicle was sold.
- b. Dollar thresholds for arbitration based upon the sale price of the vehicle:
 - i. For vehicles with a purchase price under \$50,000, the repair cost for any single undisclosed or unannounced mechanical defect to be eligible for arbitration is \$800 or more.
 - ii. For vehicles sold at a purchase price of \$50,000 or greater, the repair cost for any single undisclosed or unannounced mechanical defect to be eligible for arbitration is two percent (2%) of the purchase price or more.
- c. A buyer is only allowed one opportunity in time per vehicle purchase to file an arbitration claim for mechanical defects.
 - i. During this one opportunity, the buyer may include multiple mechanical defects in the arbitration claim, provided that each individual defect independently meets the arbitration threshold defined in section 2 (b) above.
 - ii. This limitation applies only to mechanical defects and does not restrict a buyer's ability to file a separate claim for structural damage or vehicle history issues within the timelines specified in Appendix I.
- d. The auction will only inspect the mechanical defect(s) on the initial arbitration claim. For purposes of the dollar thresholds for arbitration, the repair cost will be determined by the auction based upon the local auction/wholesale cost to repair the defect(s).
- e. If the auction-determined outcome of the arbitration claim is a price adjustment accepted by the seller and the buyer, the buyer becomes the owner of the vehicle and the vehicle is no longer eligible for arbitration for mechanical defects.
- f. The auction decision on all arbitration claims is final and binding for both the buyer and seller.

3 Fees

Auction reserves the right to assess an arbitration claim fee to the buyer. Further, if the auction approves the buyer's arbitration claim, auction reserves the right to assess an arbitration fee to the seller in addition to any sales price adjustments or other charges associated with the arbitration.

4 Arbitration Limitations

- a. **Vehicles Exceeding 20 Model Years** By default, vehicles exceeding 20 model years (with current calendar year counting as year one) are sold "As-Is" unless otherwise stated or represented by the seller.
- b. **Trailers, RVs, Watercraft, Motorcycles & Other** These units cannot be arbitrated if they exceed 10 model years (with current calendar year counting as year one).
- c. **Kit / Homemade / Modified Vehicles** These units are sold "As-Is" and cannot be arbitrated for mileage and odometer issues, structural damage, missing warranty books, or model year errors.
- d. **Inherent Conditions** No arbitration can be based on conditions inherent or typical to a particular model or manufacturer. Manufacturer guidance will be used, if applicable, to determine inherent conditions.
- e. **Manual Transmissions** Vehicles with standard (full or partial shift) transmissions cannot be arbitrated for manual clutch assemblies unless the defect will not allow a safe test drive.
- f. **Wearable Items** The buyer cannot file an arbitration claim on a vehicle for wearable items or for excessively worn or inoperative wearable items. Wearable items are defined as parts of the vehicle that the manufacturer identifies as needing replacement or adjustment during the expected life of the vehicle based upon the manufacturer's mileage guidelines. These items are normally identified in the owner's manual for routine check and replacement and would include, but are not limited to, tires, wipers, belts, brake pads, shoes, rotors, bulbs, filters, timing belts, shocks, struts, air ride or other suspension components, and fluids/lubricants.
- g. **Vehicle History Reports** The buyer cannot file an arbitration claim on a vehicle based solely upon information provided in vehicle history reports. Auction and seller are not bound by information listed in vehicle history reports. However, the auction may utilize vehicle history reports for relevant information that may assist with arbitration investigations. Examples include AutoCheck, Carfax, NMVTIS, etc.



- h. Vehicle Grades & Scoring Systems** Auction and seller are not bound by vehicle grades or other types of scoring systems. Buyers may only arbitrate a vehicle based upon undisclosed damage or defects that were present at the time of the sale.
- i. Mileage Restriction** Local auction policy defines the allowable miles from time of sale to determine whether a vehicle is still eligible for arbitration.
- j. Vehicle Accessories (For Vehicles Over 4 Model Years Old)** The buyer cannot file an arbitration claim for accessories on a vehicle that is over 4 model years old (with current calendar year counting as year 1). A Vehicle Accessory is defined as “optional or non-essential equipment or components that are not required for the basic operation and function of the vehicle.” Vehicle accessory examples include entertainment systems, power windows, heated seats, navigation systems, sunroofs/moonroofs, etc. For example, as of 2026, vehicle accessories for vehicle model years of 2022 and older are not eligible for arbitration.
- k. Oil Leaks** Arbitration claims for oil leaks that are NOT actively dripping and identifiable by visual inspection will be denied.
- l. Advanced Driver-Assistance Systems (“ADAS”)** The buyer cannot file an arbitration claim for ADAS systems and components that are integrated into parts (e.g., bumpers, mirrors, windshields, etc.) which are visibly damaged or were disclosed/announced at time of sale as damaged.

5 Force Majeure As relates to responsibility for risk of loss relative to a Force Majeure event (defined as including, but not limited to, the following: any act of God, fire, flood or other weather-related event, earthquake, riot, insurrection, sabotage, war, terrorism, power outage, etc.), the auction disclaims, and the buyer and seller agree to such disclaimer, any such responsibility or liability. As between buyer and seller, responsibility for such risk resides with the seller until the hammer drops at the time the final winning bid is accepted, at which time said responsibility will become that of the buyer. In the event of a successful arbitration by the buyer after the drop of the hammer at the time the final winning bid is accepted, responsibility will revert to the seller at the time the final arbitration decision is made by the auction, but it will not alter the above allocation of responsibility existing at the time of the force majeure event. The above notwithstanding, the auction reserves the right, in its sole discretion, to consider all equities surrounding a sale in making its final decision as to assignment of such responsibility.

6 Indemnification Seller and buyer agree to indemnify and hold auction harmless from any liability, loss, costs, damage or expense (including attorney fees) which may arise either directly or indirectly from the sale and purchase of the vehicle including, but not limited to, any title services provided in the event of a defect in title and in any matter relating to discrepancies or errors associated with odometer mileage, odometer statements or damage disclosure statements.

7 Subscription Services Neither the seller or the auction guarantees the transferability of options, equipment, or software services that are based on owner or user subscriptions or fee-based agreements. (i.e., Auto Pilot, Self-Driving, Satellite Radio, etc.) Furthermore, any required technical or software updates are the responsibility of the buyer and not subject to arbitration.



VI Title Arbitration Guidelines

1 Marketable Title Requirement

- a. All titles submitted by seller must be in seller's company name on the title or on a properly executed reassignment form.
- b. The seller guarantees that the title of any vehicle sold through auction shall be marketable in the state in which the vehicle is being sold. The title shall be free and clear of all liens, encumbrances, and brands (including, for example, but not limited to, "salvage," "rebuilt," "flood," etc.), unless such encumbrances or brands are or were announced at the time of sale.

2 Title Guarantee

- a. Seller warrants, represents, and guarantees possession and conveyance of a certificate of title, properly executed. Furthermore, seller warrants and will defend the title against the claims and demands of all persons.
- b. This guarantee applies to the current and any prior certificate of title and extends for a period of four (4) years from the date of sale. Seller's liability under this title guarantee shall never exceed the auction sale price (the "maximum amount") of the vehicle.
- c. This maximum amount shall be reduced (depreciated) by two percent (2%) per month following auction sale date.
- d. Depreciation application and calculation shall be determined at the sole discretion of the Auction and may be adjusted based on the nature of the claim and the specifics of the transaction.
- e. All seller liability under this title guarantee shall expire and terminate four (4) years to the day after auction sale date.
- f. If the buyer arbitrates a vehicle for late title based upon the local auction policy timeframe for delivery of title and the arbitration claim is successful, neither the seller nor the auction will be responsible for reimbursing the buyer as stated in Buyer Responsibilities IV.3.

3 Arbitration Eligibility for Encumbrances and Brands

- a. The buyer may file an arbitration claim on a vehicle for any undisclosed or unannounced lien, encumbrance, or brand that renders a title non-negotiable at the time of sale (except for current year DMV fees in California and other states).
- b. The buyer may also file an arbitration claim on a vehicle if documentation shows that a defect or encumbrance on the title at time of sale will result in a future brand and thus prevent the buyer from obtaining

a clear, marketable title in the state in which the vehicle was sold at auction.

4 Arbitration Claim Validations

Buyers must provide reasonably sufficient and verifiable evidence which could/may include:

- a. Official government motor vehicle reporting (e.g., DMV)
- b. Insurance declarations
- c. NICB reporting
- d. Law enforcement reports
- e. Prior auction history and sale announcements

5 Auction Decision Authority

Auction retains full discretion and authority to determine the sufficiency and validity of the buyer's claim and supporting evidence, and its decision shall be final and binding on both the buyer and the seller.

6 Title Reassignments

Seller will ensure that the title is reassigned directly to buyer. Titles cannot be assigned directly to the auction or facilitation service provider.

7 Payment to Sellers

Seller will not be paid for vehicles sold at auction until a valid, negotiable, and assignable title is received by the auction.

8 Bill of Sale Only Transactions

Auction accepts no responsibility for vehicles sold on bill of sale only. Seller must announce the vehicle being sold with a bill of sale only and that there is no title to transfer. All non-titled vehicles and equipment will be sold Red Light "Limited As-Is."

9 Clerical Title Errors

If a title received by the auction from the seller has a problem due to a clerical or coding error, or incomplete documentation, seller shall be given reasonable time after receiving notice to have the error corrected.

10 Title Documentation

If a vehicle is offered for sale with an application or other documentation for a duplicate title, the seller is required to disclose or announce such condition of sale unless the appropriate jurisdiction allows for the vehicle sale to occur under such conditions.



VI Title Arbitration Guidelines (Continued)

11 Foreign (non-United States) Titles

If a vehicle is offered for sale with a foreign (non-United States title) and the sale is allowed by law in the United States, the municipality and state where the auction sale occurs, the seller must disclose/announce the non-United States title. Local auction policy dictates further disclosure requirements and the time frame within which seller is required to deliver a transferrable title.

12 Title Delivery Timeline

- a. The timeline within which the seller must deliver title is determined by the local auction policy. For purposes of calculating the number of days, sale day is day 1.
- b. If the seller fails to deliver title within the timeframe specified in the local auction policy, it is the buyer's option to file an arbitration claim to void the sale transaction or continue to wait for the title.
- c. If, after 90 calendar days, seller has not produced negotiable title and buyer has not filed an arbitration claim to void the sale transaction, the auction shall have no duty to produce the certificate of title to the buyer and shall have no duty to pay the seller.

13 Title Attached/Title Unavailable/Title Absent ("TA" in each instance) Disclosures

Vehicles lacking a properly assigned title or reassignment to transfer the title at time of sale must be sold under the blue light (TA).

14 Missing Lien Release Disclosures

Vehicles lacking lien release or a valid repossession affidavit for a repossessed vehicle (where allowed by law) must be sold under the blue light (TA).

15 Buyer Reimbursement

Neither the seller nor the auction will be liable (under any circumstances) to the buyer for lost profits, commissions, marketing, repairs, reconditioning costs or other expenses incurred by the buyer while waiting for delivery of the title.

16 Title in Transit

If the buyer files an arbitration claim on a vehicle for late title and the title has been received by the auction and/or the title is in-transit to the buyer, the claim will be denied, and the buyer may not attempt to return the vehicle to the auction.

17 Next-Day Title Remedy

In the event that the buyer files an arbitration claim on a vehicle for late title and the seller presents a valid negotiable title to the auction on the next business day (excluding weekends and auction observed holidays) following the expiration of the local auction's time period for delivery of title, then the claim will be denied.

18 Title Claim Notification

Whenever any claim is made by any person against the title of a vehicle, whether by suit or otherwise, the buyer, immediately after becoming aware of said claim, shall (1) notify the auction; (2) provide all details of the claim; (3), cooperate fully to defend any legal action, and (4) taking any other reasonable and necessary steps to minimize possible loss.

19 Lemon Law Buyback Contingencies

For vehicles offered for sale with a Manufacturer/Lemon Law Buyback disclosure, the seller must also disclose any contingencies or additional requirements that the buyer must meet to receive the title (e.g., signed disclosures or acknowledgements from subsequent retail consumers or any other requirement).



VII Previous Canadian and/or Grey Market Vehicles

1 Previous Canadian Disclosure

A "Previous Canadian" disclosure is required for any vehicle (regardless of manufacturing origin) having been registered in a Canadian province. Additional announcements may be required due to vehicle use in Canada (i.e., full or partial voided warranty, foreign title, etc.).

2 Grey Market Vehicles

Any vehicle not originally built to U.S. specifications can, under certain circumstances as dictated by the federal government, be imported through a registered importer who modifies the vehicle to comply with U.S. equipment and safety regulations (e.g., United States Department of Transportation ("USDOT"), the National Highway Transportation Safety Administration ("NHTSA") and/or other federal agencies) and then certifies it as compliant, and an independent commercial importer who modifies the vehicle to comply with U.S. emissions regulations and then certifies it as compliant. Only vehicles properly converted to U.S. specifications can be offered for sale and must be disclosed/announced as such.

3 Required Conversion

- a. All other vehicles imported must be imported through a registered importer who is required to post a bond with USDOT and/or NHTSA.
- b. All vehicles imported through a Registered Importer must have:
 - i. A U.S. Safety Standard Certification Label that identifies the Registered Importer
 - ii. A valid U.S. Title or foreign title that is legally accepted in the U.S.
 - iii. Met all NHTSA, USDOT US EPA and/or other federal agency mandated guidelines
 - iv. Documentation provided by seller at time of sale and anytime thereafter.
 - v. Cleared the mandated wait time
- c. All vehicles, whether imported by a manufacturer or a registered importer, must show miles per hour on the speedometer and total miles traveled on the odometer. Replacement of an odometer under allowable circumstances (Title 49, USC Chapter 327, Section 32704) does not have to be announced by the seller.



Arbitration Guidelines - Appendix I Effective June 1, 2026

NAAA Seller Disclosure/Announcement	Disclosure/Announcement Required			Arbitration Time Periods (if applicable)	
	Green Light Only	Yellow Light Only	Red Light Only		
	"Ride & Drive"	"Limited Guarantee"	"Limited As-Is"		
This appendix is not all-inclusive. See the full guidelines for additional context on these and other elements.					
Major Components					
Fuel Conversion	YES	YES	YES	B or C	
Electric or Hybrid Vehicle Battery Problem (up to eight (8) model years)*			NO	NO	A or C
Engine Problem*					
Cracked or Repaired Block*					
Transmission/Drive Train Problem*					
Front or Rear Differential*					
4X4 System Inoperable*					
Significant Mechanical Modifications or Alterations					
ABS Problem*		NO	NO	B or C	
Emission Control Equipment: Inoperable, missing, or altered components that change or disable its function as intended by the manufacturer*					
Air Conditioning System*					
SRS – Missing or Problem with Airbags*					
Advanced Driver Assistance Components (ADAS)					
Non-original engine or electric vehicle batteries for current model year and up to 4 model years old. (Excludes items replaced under manufacturer's warranty.)					
Vehicle History Issues					
Structural Damage/Certified Structural Repair or Replacement/Structural Alteration per NAAA Structural Component Guidelines	YES	YES	YES	B or C	
Inoperative Odometer Display (Miles remain certified by seller)					
State-Issued VIN Plates (Including Kit Vehicles)					
Vehicles Being Sold with No Title (Bill of Sale Only)				A or C	
Logo or Decal Misrepresentation					
Fire Damage					
Biohazard Vehicles – Existing and/or Non-Remediated					
Stolen Vehicle/Theft Recovery (Including History)					
Flood Damage (By Auction Inspection)					
Previous Canadian Vehicles					
Total Loss and/or Salvage Retention (By Insurance Records)**					
Not Actual Miles or True Miles Unknown**					
Stolen Vehicle - Active/Open Theft **					
Lemon Law/Manufacturer's Buyback**					
Bonded, Insurance and/or Salvage Titles (Including History)**					
Grey Market Vehicles**					
Flood Damage History (Reported By Government Agencies and/or Insurance Company Records)				120 Days	
All Taxes and Livery Requiring Local or State Licenses and Law Enforcement Vehicles					
Voided Factory Warranty					
Other Issues					
Vehicles Being Sold With a Government Release for Title ,(27A, SF-97-1etc.), CO, MSO, or Repo Affidavit Title (If Required By Law)	YES	YES	YES	7 Days After Receipt of Title	
Pending State or Local DMV Fees or Taxes Over \$100 Due On Vehicle (If Required By Law)					
Any Disclosure Required By Law					
Convertible Tops*	YES	NO	NO	A or C	
Vehicle Accessory Problems* - Up to four (4) Model Years Old					
Exterior Cosmetic Wraps that Exceed 50% of Vehicle Exterior Panels					
Paintwork (3 Panels or More) on Current Model Year and Newer (Excludes Bumpers)					
Vehicles Not Equipped With Air Conditioning, Excludes Vehicles ten (10) Model Years Old or Older.					
Arbitration Time Period Per Sale Channel Breakdown (Subject to local auction policy.)					
"A" Inlane-Sale Day Only "B" Inlane-7 Calendar Days Only "C" Online-Minimum industry standard = 7 calendar days Sale Day = Day 1 for all timelines					
* Defects with a repair or replacement cost of \$800 or more must be disclosed (2% threshold applies to vehicles sold for \$50,000 or more).					
** These transactions may be subject to arbitration regardless of the stated time limits. Arbitration claims initiated after the stated time period will be addressed under the guidelines of the "Title Arbitration Guidelines" (Paragraph I) and subject to the referenced depreciation terms.					



VIII Structural Component Guidelines

The purpose of the NAAA Structural Component Guidelines is to define and clarify terminology associated with structural issues and to specify the disclosure requirements of the seller for vehicles offered at NAAA affiliated auctions. The guidelines are intended to provide adequate disclosure to the buyer for informed purchase decisions and to limit arbitrations for the seller. These guidelines, along with the main Arbitration Guidelines, will serve as the primary criteria for all arbitration proceedings.

1 Definitions

- a. **Vehicle Structure** — The main load-bearing platform of a vehicle that gives strength, stability and design exclusivity and to which all other components of the vehicle are fastened. Three macro types: (i) Unibody — floor pan assembly, roof bows/braces, pillars bonded into one unit; (ii) Unibody on Frame — unitized structure bolted to a conventional structure; (iii) Conventional Structure — two symmetrical rails connected by various cross-members.
- b. **UVMS** — Used Vehicle Measurement Standard. The commercially acceptable measurement deviation from the vehicle's original structural specification in order for any deviation not to be considered structural damage.
- c. **Permanent Damage** (aka "Kinked" or "Broken") — The result of two or more objects striking or coming together at a significant change in velocity that permanently deforms the structural component(s) rendering it non-repairable per the manufacturer.

2 Recommended Disclosures

- a. **Structural Damage** — Damage to the structure or a specific structural component of the vehicle. Often referred to as frame damage, although it also applies to Unibody and Unibody on Frame structures in addition to Conventional Frame.
- b. **Certified Structural Repairs/Replacement** — Repairs to a specifically identified structural component that has been certified to be within the Used Vehicle Measurement Standard (UVMS).
- c. **Structural Alteration** — An alteration to the vehicle's structure including a lengthened or shortened frame, a modified suspension, or the installation or removal of after-market accessories.

3 Seller Disclosure Requirements

Sellers must disclose permanent structural damage, any structural alterations, structural repairs or replacements (certified or non-certified) as outlined in these guidelines prior to selling a vehicle at auction regardless of sales channel or light condition. Disclosures are required for the following:

- a. Any/all existing permanent (non-repairable aka kinked or broken) structural damage as defined in these guidelines.
- b. Improper and/or substandard prior repairs (not meeting OEM repair guidelines).
- c. Repairs not certified using OEM guidelines or to be within the UVMS; improper alterations to the structure; lengthened or shortened structure verified by visual inspection.
- d. Altered suspension that requires the structure to be modified from its OEM form.
- e. After-market accessories installed or removed to the structure.
- f. Towing packages installed (or removed) where new holes are drilled, OEM holes are enlarged, or if the towing package is welded or brazed to the structure.
- g. Multiple access holes (regardless of size) or singular access holes greater than 5/8". Access holes between 1/4" and 5/8" are subject to disclosure based upon location and condition.
- h. Corrosion of structural components when the substrate loses its shape, original bonds are loose, original thickness changed by more than 25%, or the area no longer possesses its absorption or deflection properties.
- i. Structural tear damage (i.e., transport tie down) if more than 1" in length.
- j. Damage due to improper jacking or lifting that permanently deforms structural components.
- k. Damage due to contact with parking abutments and/or road debris that permanently deforms structural components.
- l. Roof bows/braces that have been modified, have existing permanent damage, or removed. A replaced roof skin is not a required disclosure.
- m. The C pillar/quarter or Cab panel may or may not be a structural component(s) as per the vehicle manufacturer.



VIII

Structural Component Guidelines (Continued)

4 Arbitration Rules for Structural Damage

- a. A vehicle may be arbitrated if it has undisclosed existing permanent damage alteration, Certified Repairs or Certified Replacement, which should have been disclosed under these guidelines, even though the vehicle is within the UVMS. If a structural issue is properly disclosed, the vehicle may only be arbitrated for improper repair of the designated area, existing permanent damage or repairs to other areas of the vehicle not disclosed, or for failure to be within the UVMS that was verified by visual inspection.
- b. Damaged or replaced radiator core supports or rear body panels do not require a structural disclosure under these guidelines.
- c. Damage to the aprons, rail floor pan assembly, inner wheelhouse (upper or lower), D pillar (if equipped) or other ancillary structural components on a unitized structure in the area where the radiator core support or rear body panel attaches will require a disclosure if permanent damage exists.
- d. Brazed exhaust hangers are not a required disclosure under these guidelines.
- e. Facilitating auction will, at its discretion, have a vehicle measured according to the UVMS at a facility of its choice. Prior to sending the vehicle for measurement, the auction reserves the right to complete a visual verification of the physical condition of the vehicle to determine that it should be measured. If the measuring facility determines that the vehicle is within the UVMS, the buyer of the vehicle will be responsible for the charges paid to the facility. Likewise, if the measuring facility determines that the vehicle is not within the UVMS, the seller will be responsible for the charges paid to the facility.
- f. Visual evidence supersedes any/all mechanical or electronic measurements.
- g. For measurements according to the UVMS, the following guidelines will apply:
 - i. The vehicle structure must measure to a total tolerance of no more than +/- 8 millimeters (mm) of published specification of length, width and height at control points that capture the front (2), center (4) and rear (2) sections of the vehicle.
 - ii. Symmetrically (comparative measure from side to side and point to point based on point measurement), the length, width and height must measure to a difference of no more than 6 mm. Upper body measurements (tram gauge) by themselves will not be adequate.
- h. Buyer must arbitrate any and all structural misrepresentations as outlined in these guidelines within published timelines (outlined in the main Arbitration Guidelines) from date of purchase (purchase day counts as Day One).
- i. The buyer must contact and follow the arbitration process of the auction where the vehicle was purchased, including the auction's direction for return of the vehicle and the timeframe allowed.
- j. In the event of improperly disclosed structural damage by the seller, the buyer will be entitled to reimbursement in accordance with the main Arbitration Guidelines.

Structural Components	Structural Damage Disclosure Requirement		
	Unibody	Unibody on Conventional Structure	Conventional Structure
1. Frame Rails (Including Front, Center and Rear Rails)	Existing Permanent Damage, Removed, Modified, Repaired or Replaced		
2. Spring Pod, Torque Box or Stabilizer Mount	N/A	Existing Permanent Damage, Removed, Modified, Repaired or Replaced	
3. Cross Members (Except Bolt-On)	Existing Permanent Damage, Removed, Modified, Repaired or Replaced		
4. Apron Assembly	Existing Permanent Damage, Removed, Modified, Repaired or Replaced		N/A
5. Strut Tower Assembly	Existing Permanent Damage, Removed, Modified, Repaired or Replaced		N/A
6. Cowl Panel/Firewall	Existing Permanent Damage, Removed, Modified, Repaired or Replaced		N/A
7. Support Pillars (Includes A, B, C, D)	Existing Permanent Damage, Removed, Modified, Repaired or Replaced		
8. Roof Braces/Bows	Existing Permanent Damage, Removed, Modified, Repaired or Replaced		
9. Rocker Panel (Outer)	Replacement Only		N/A
10. Rocker Panel (Inner)	Existing Permanent Damage, Removed, Modified, Repaired or Replaced		N/A
11. Floor/Trunk Panels	Tears 1" or More, Existing Permanent Damage, Removed, Modified, Repaired or Replaced Panels		N/A
12. Quarter* or Cab* Panel	Replacement Only		N/A
13. Inner Quarter Panel Assembly (Includes Inner Wheelhouse Panel, Rear Strut Tower, and Wheelhouse Extension Lower)	Existing Permanent Damage, Removed, Modified, Repaired or Replaced		N/A

* Only Applies to Components Deemed Structural Per the Vehicle Manufacturer.

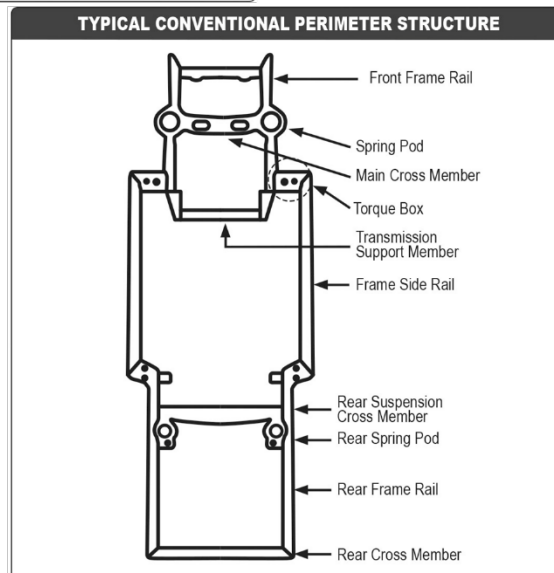
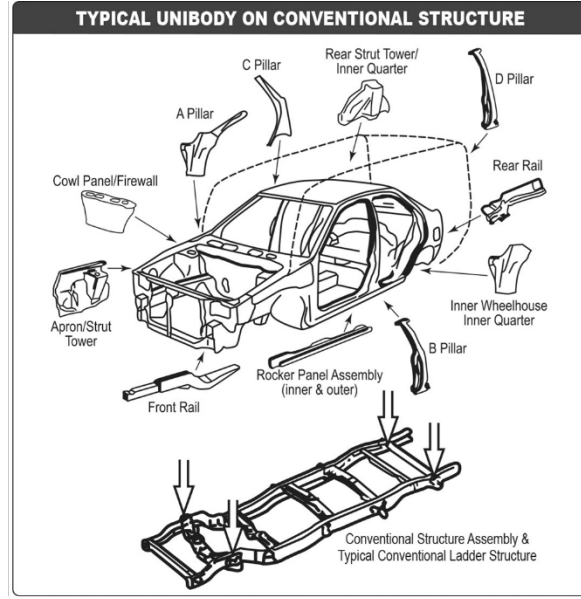
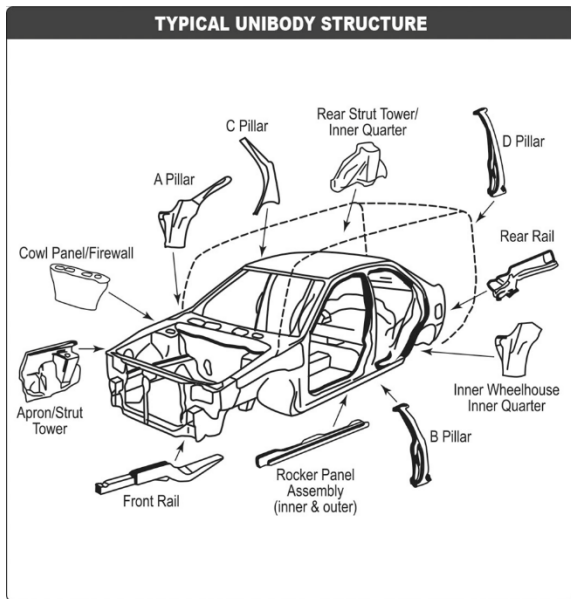



IX Flood Damage Guidelines

Vehicles are frequently exposed to moisture during their ordinary operation, maintenance, and reconditioning. Occasionally, such exposure may leave residual marks or indicators similar to those left by exposure or immersion of the vehicle in floodwater. In determining what conditions require disclosure/announcement and in evaluating an arbitration claim by a buyer for flood exposure/damage it is critical that the total condition of the vehicle be considered including VIN data history. Disclosure requirements can be found in Appendix I.

1 Disclosure/Announcement Not Required by Seller

No disclosure/announcement is required and, likewise, no arbitration is allowed by the buyer for the following types of water exposure, provided that none of the components outlined below are damaged:

- a. Rain, snow or sleet that entered the vehicle due to open windows, doors or tops or leaking seals.
- b. Moisture due to a car wash or rinse.
- c. Moisture due to carpet or upholstery shampooing or cleaning.
- d. Exterior contact with a water source (including, but not limited to, rivers, streams, creeks, lakes, ponds, puddles or floodwater) so long as the exterior water did not rise above the rocker panel or enter the passenger compartment of the vehicle.
- e. Exterior contact with a water source (including, but not limited to, rivers, streams, creeks, lakes, ponds, puddles or floodwater) that enters the storage/luggage compartment but does not damage any components (such as electrical, lighting or wiring harnesses) or enter the passenger compartment.

2 Disclosure/Announcement Required by Seller

Disclosure/announcement is required and buyer may make an arbitration claim for undisclosed/unannounced damage under the following conditions:

- a. The title has been correctly branded indicating flood history of the vehicle.
- b. Any of the following components have been damaged due to floodwater immersion/ingress:
 - i. Front or rear internal lighting or wiring harnesses
 - ii. Engine and its major components
 - iii. Transmission and differential
 - iv. Dash instrument panel and wiring
 - v. Passenger seating
 - vi. Power seats or windows
 - vii. Sound and infotainment systems